

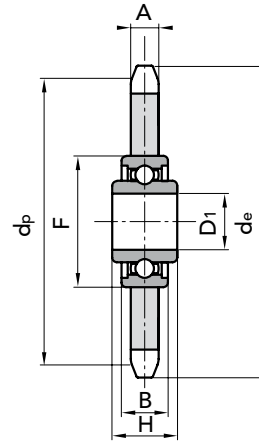

WITH BEARING

INA KRR-AH02-C5

Our chain tensioning sprockets are supplied complete with bearing, ready for assembly in special tension or transmission points. The accurate machining and stable assembly on a dual protective shield ball bearing ensure greater resistance to loads and wear. The central elongated ring of the bearing facilitates assembly on special machines of every type.



Z	PITCH	d _e	d _p	PART NUMBER	A	D1	F	B	H	kg.
23	8 x 3	62,15	58,75	30008123	2,8	16 $^{+0,26}_{+0,13}$	40	12	18,3	0,13
21	3/8" x 7/32"	68,00	63,90	30009121	5,3	16 $^{+0,26}_{+0,13}$	40	12	18,3	0,15
18	1/2" x 1/8"	78,90	73,14	30010118	3,0	16 $^{+0,26}_{+0,13}$	40	12	18,3	0,18
18	1/2" x 3/16"	78,90	73,13	30011118	4,5	16 $^{+0,26}_{+0,13}$	40	12	18,3	0,20
16	1/2" x 5/16"	69,50	65,10	30012116	7,2	16 $^{+0,26}_{+0,13}$	40	12	18,3	0,17
18	1/2" x 5/16"	77,80	73,14	30012118	7,2	16 $^{+0,26}_{+0,13}$	40	12	18,3	0,22
14	5/8" x 3/8"	78,00	71,34	30015114	9,1	16 $^{+0,26}_{+0,13}$	40	12	18,3	0,23
15	5/8" x 3/8"	83,00	76,36	30015115	9,1	16 $^{+0,26}_{+0,13}$	40	12	18,3	0,27
17	5/8" x 3/8"	93,00	86,39	30015117	9,1	16 $^{+0,26}_{+0,13}$	40	12	18,3	0,36
13	3/4" x 7/16"	87,50	79,59	30019113	11,1	16 $^{+0,26}_{+0,13}$	40	12	18,3	0,34
15	3/4" x 7/16"	99,80	91,63	30019115	11,1	16 $^{+0,26}_{+0,13}$	40	12	18,3	0,47
12	1" x 17.02	109,00	98,14	30025112	16,2	20 $^{+0}_{+0,1}$	47	14	17,7	0,72
13	1"1/4 x 3/4"	147,80	132,65	30031113	18,5	25 $^{+0}_{+0,1}$	52	15	21,0	1,64



CAD drawings available on our site
www.chiaravalli.com5

Quantity, availability and prices
 on B2B Chiaravalli



WITH ECONOMIC BEARING

Our chain tensioning sprockets are supplied complete with bearing, ready for assembly in special tension or transmission points. The accurate machining and stable assembly on a dual protective shield ball bearing ensure greater resistance to loads and wear. The central elongated ring of the bearing facilitates assembly on special machines of every type.

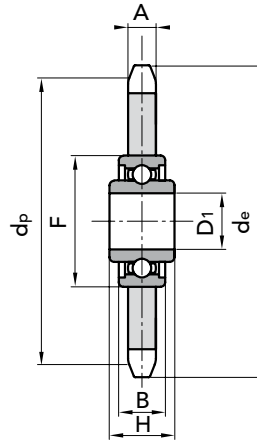

Z	PITCH	d _e	d _p	PART NUMBER	A	D1	F	B	H	kg.
23	8 x 3	62,15	58,75	30008023	2,8	16 $\begin{smallmatrix} +0,26 \\ +0,13 \end{smallmatrix}$	40	12	18,3	0,13
21	3/8" x 7/32"	68,00	63,90	30009021	5,3	16 $\begin{smallmatrix} +0,26 \\ +0,13 \end{smallmatrix}$	40	12	18,3	0,15
22	3/8" x 7/32"	71,00	66,93	30009022	5,3	16 $\begin{smallmatrix} +0,26 \\ +0,13 \end{smallmatrix}$	40	12	18,3	0,16
18	1/2" x 1/8"	78,90	73,14	30010018	3,0	16 $\begin{smallmatrix} +0,26 \\ +0,13 \end{smallmatrix}$	40	12	18,3	0,18
15	1/2" x 3/16"	66,80	61,09	30011015	4,5	16 $\begin{smallmatrix} +0,26 \\ +0,13 \end{smallmatrix}$	40	12	18,3	0,16
16	1/2" x 3/16"	70,90	65,10	30011016	4,5	16 $\begin{smallmatrix} +0,26 \\ +0,13 \end{smallmatrix}$	40	12	18,3	0,17
18	1/2" x 3/16"	78,90	73,13	30011018	4,5	16 $\begin{smallmatrix} +0,26 \\ +0,13 \end{smallmatrix}$	40	12	18,3	0,20
14	1/2" x 5/16"	61,80	57,07	30012014	7,2	16 $\begin{smallmatrix} +0,26 \\ +0,13 \end{smallmatrix}$	40	12	18,3	0,13
16	1/2" x 5/16"	69,50	65,10	30012016	7,2	16 $\begin{smallmatrix} +0,26 \\ +0,13 \end{smallmatrix}$	40	12	18,3	0,17
18	1/2" x 5/16"	77,80	73,14	30012018	7,2	16 $\begin{smallmatrix} +0,26 \\ +0,13 \end{smallmatrix}$	40	12	18,3	0,22
14	5/8" x 3/8"	78,00	71,34	30015014	9,1	16 $\begin{smallmatrix} +0,26 \\ +0,13 \end{smallmatrix}$	40	12	18,3	0,23
15	5/8" x 3/8"	83,00	76,36	30015015	9,1	16 $\begin{smallmatrix} +0,26 \\ +0,13 \end{smallmatrix}$	40	12	18,3	0,27
17	5/8" x 3/8"	93,00	86,39	30015017	9,1	16 $\begin{smallmatrix} +0,26 \\ +0,13 \end{smallmatrix}$	40	12	18,3	0,36
13	3/4" x 7/16"	87,50	79,59	30019013	11,1	16 $\begin{smallmatrix} +0,26 \\ +0,13 \end{smallmatrix}$	40	12	18,3	0,34
15	3/4" x 7/16"	99,80	91,63	30019015	11,1	16 $\begin{smallmatrix} +0,26 \\ +0,13 \end{smallmatrix}$	40	12	18,3	0,47
12	1" x 17.02	109,00	98,14	30025012	16,2	20 $\begin{smallmatrix} +0 \\ +0,1 \end{smallmatrix}$	47	14	17,7	0,72
13	1" 1/4 x 3/4"	147,80	132,65	30031013	18,5	25 $\begin{smallmatrix} +0 \\ +0,1 \end{smallmatrix}$	52	15	21,0	1,64



Quantity, availability and prices
on B2B Chiaravalli





The automatic tensioners series **CHT-AS** and their relating variants (that you can find in the following pages) keep the tension of the chains or belts constantly tensioned recovering axially the extension of the same, through multiple compression springs contained inside the basic body.

The structural parts are die-cast high-tensile aluminum body frame painted by means of the cataphoresis process.

The dry self-lubricating bushings with standard PTFE in all sizes and versions, provide perfect surfaces for the pins sliding, without any wear.

Flexible items and springs elements in steel league, provide a constant tension.

Simple assembling with the possibility to preload the tensioner through the frontal hole.

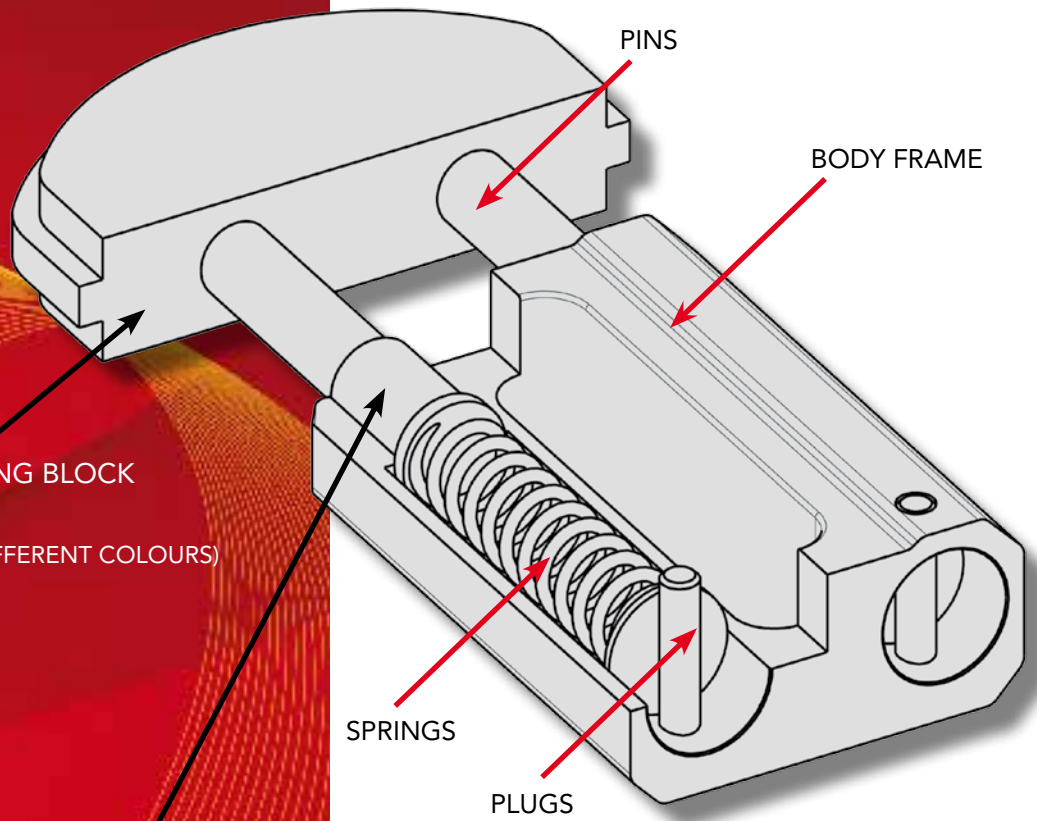
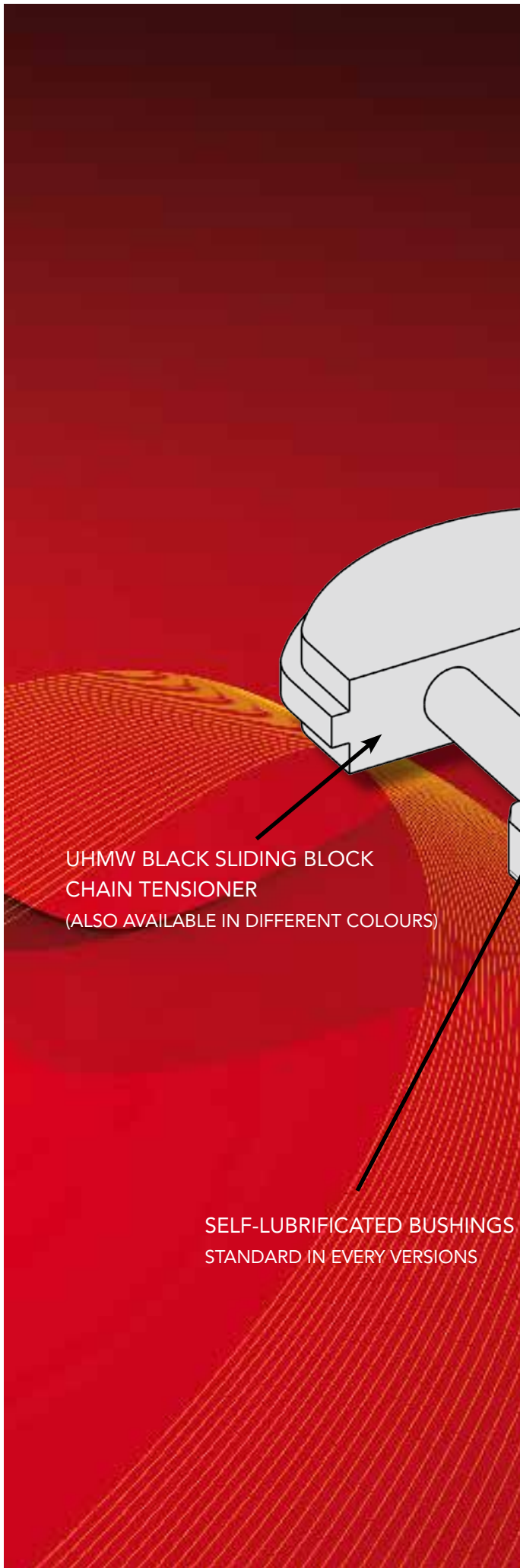

UHMW BLACK SLIDING BLOCK
CHAIN TENSIONER
(ALSO AVAILABLE IN DIFFERENT COLOURS)

SELF-LUBRICATED BUSHINGS
STANDARD IN EVERY VERSIONS





ROTATING TENSIONER BRAND CHT®





The automatic tensioners series **CHT-T** and their relating variants (that you can find in the following pages) keep constant tension of the chains or belts constantly tensioned.

The two structural body parts are die-cast high-tensile aluminum beads pointed of black, by means of the cataphoresis process.

The bronze self-lubricating bushings, standard sintered, on all sizes versions, provide perfect surfaces for the lever movement around the pin without wear points.

Flexible items and springs elements in steel league provide a constant tension. The springs are lubricated with grease to assure duration and silent operations.

Simple assembling through a single screw, that can be assembled on both sides.

Frame adjustment provided for an easy and fast tension adjustment, by means of holes.

The body frame is provided with arm and two adjustments holes for a wide tension.

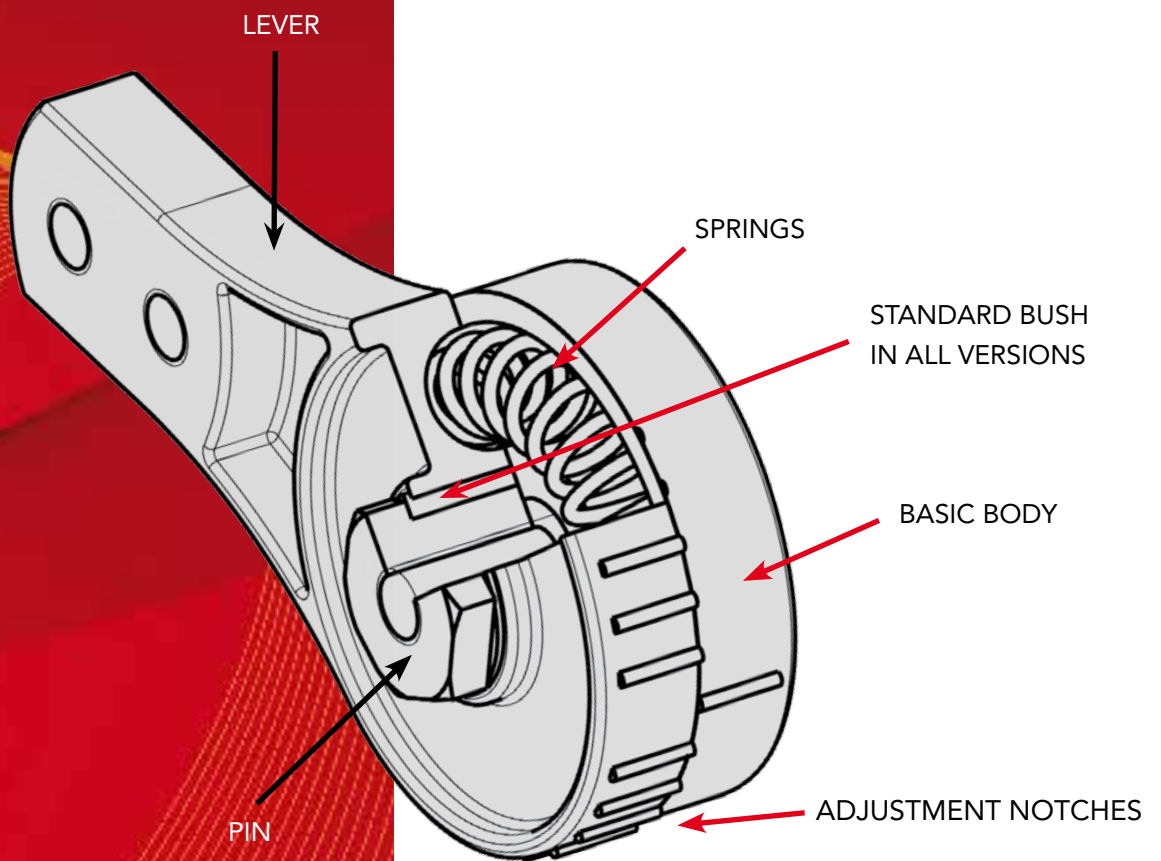



SERIES T

- 1) Loosen slightly fixing screw "A", that can be fixed on both sides.
- 2) Rotate the tensioner "B" in the desired direction with a spanner of 24 mm, situated on the central hexagon.
- 3) Stop the screw "A".

NOTE

In case of irregular surfaces or heavy applications, it is advisable to use an anti-rotation pin, to be inserted in one of the two hollows present on the back side of the tensioner base.

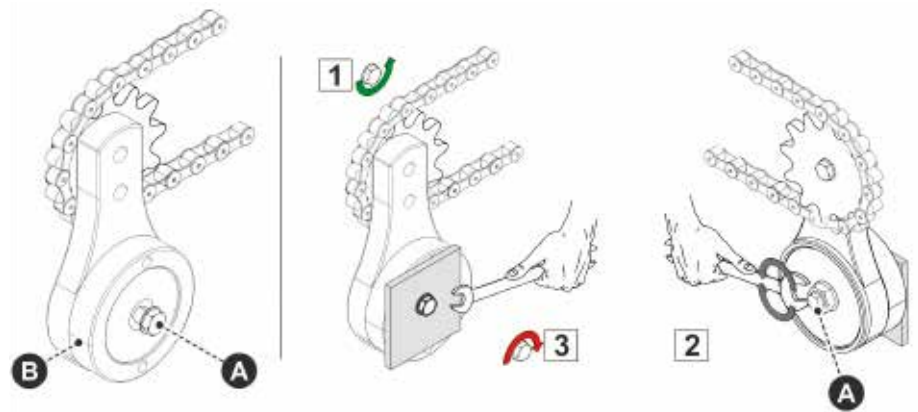

SERIES AS - SERIES L

- 1) Preload the tensioner "A".
- 2) Compress springs.
- 3) Insert a pin "B" in the frontal hole, present on the basic frame.
- 4) Fix the locking screw "C" in the highest slot point to allow, if necessary, the displacement of the tensioner onwards.
- 5) Pull out the pin "B".

NOTE

In case of irregular surfaces or heavy applications, it is advisable the use of two security screws, to avoid the tensioner rotation.

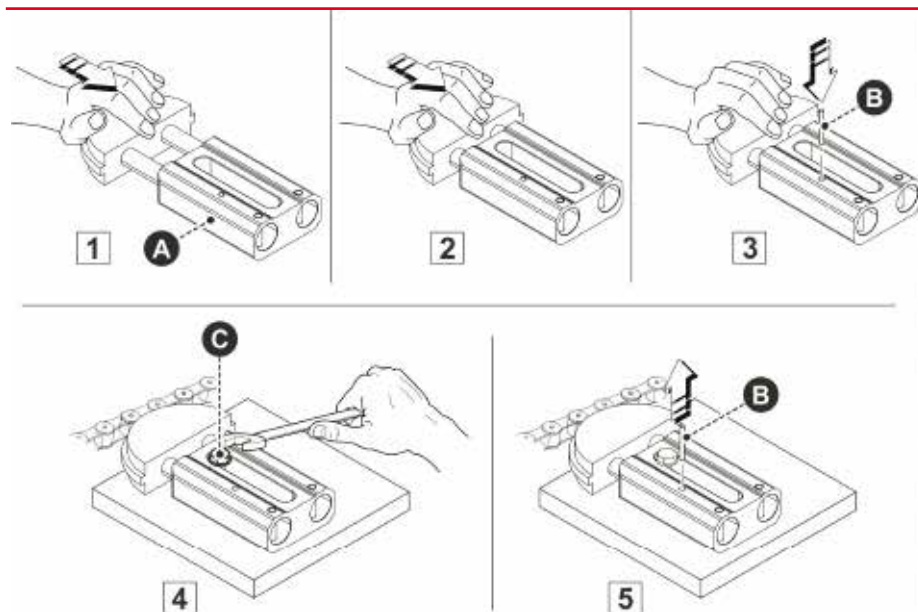



NEW

- Tensioner mod. T with two holes for the accessories fixing
- Bronze self-lubricating sintered bushings
- On request available with stainless steel pin and springs

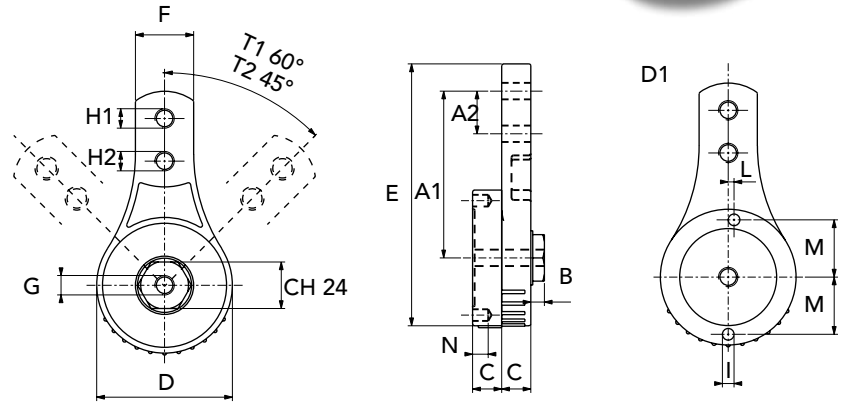

TYPE	P. NUMBER	Hm H1	Newton H2	A1	A2	B	C	D	E	F	G	H1	H2	I	L	M	N	WEIGHT Kg.
T1 8.5	94030108N	180	250	86	22	7	15	70	135	30	M10	8,5	8,5	6	3	29,5	8	0,36
T1 10	94030110N	180	250	86	22	7	15	70	135	30	M10	M10	M10	6	3	29,5	8	0,36
T1 10.5	94030111N	180	250	86	22	7	15	70	135	30	M10	10,5	10,5	6	3	29,5	8	0,36
T1 12	94030112N	180	250	86	22	7	15	70	135	30	M10	M12	M12	6	3	29,5	8	0,34
T1 16	94030116N	180	250	86	22	7	15	70	135	30	M10	M16	M16	6	3	29,5	8	0,30
T2 10.5	94030211N	340	440	100	22	7	18	90	160	35	M12	10,5	10,5	8	-	37,5	10	0,62
T2 12	94030212N	340	440	100	22	7	18	90	160	35	M12	M12	M12	8	-	37,5	10	0,62
T2 16	94030216N	340	440	100	22	7	18	90	160	35	M12	M16	M16	8	-	37,5	10	0,60
T2 20	94030220N	340	440	100	22	7	18	90	160	35	M12	M20	M20	8	-	37,5	10	0,58

NEW



ROTATING TENSIONER **CHT-T**

NEW
Chain Tensioner CHT - TTN

- Tensioner mod. T with sprocket chain tensioner TN (simple)
- Bronze self-lubricating sintered bushings
- On request version with stainless steel pin and springs

Chain Tensioner CHT - TR

- Tensioner T with sprocket chain tensioner R (simple, duplex, triplex)
- Standard sintered bronze self-lubricating bushings
- On request available with stainless steel pin and springs

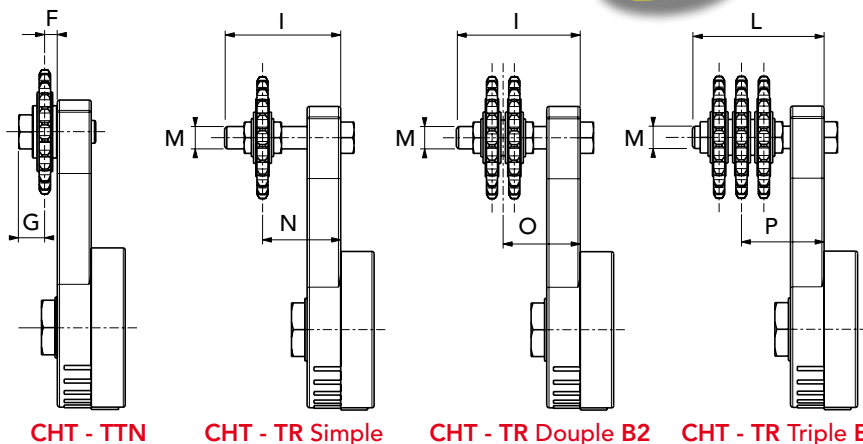
CHT - TTN
CHT - TR Simple
CHT - TR Double B2
CHT - TR Triple B3
CHT - TTN

TYPE	P. NUMBER	STEP CHAIN	Z TEETH	F	G	M	WEIGHT Kg.
TTN1-3/8	94030921	3/8"X 7/32"	21	9,2	19,2	M12	0,55
TTN1-1/2	94031216	1/2"X5/16"	16	9,2	19,2	M12	0,57
TTN1-5/8	94031517	5/8"X3/8"	17	9,2	19,2	M12	0,76
TTN2-5/8	94031518	5/8"X3/8"	17	9,2	19,2	M12	1,04
TTN2-3/4	94031915	3/4"X7/16"	15	9,2	19,2	M12	1,15
TTN2-1	94032512	1"X17mm	12	8,9	19	M12	1,45

CHT - TR

TYPE	P. NUMBER SIMPLE	P. NUMBER DOUBLE	P. NUMBER TRIPLE	STEP CHAIN	Z TEETH	I	L	M	N	O	P	WEIGHT Kg.
TR1-3/8	94030901	94030902	94030903	3/8"X 7/32"	15	60	80	M10	40-63	48-57	53-72	0,50
TR1-1/2	94031201	94031202	94031203	1/2"X5/16"	15	60	80	M12	40-63	50-55	57-68	0,55
TR1-5/8	94031501	94031502	94031503	5/8"X3/8"	15	80	80	M12	40-80	54-71	60-65	0,70
TR2-5/8	94031511	94031512	94031513	5/8"X3/8"	15	80	80	M12	46-84	59-82	68-84	0,97
TR2-3/4	94031901	94031902	94031903	3/4"X7/16"	15	80	100	M12	46-84	59-82	68-84	1,25
TR2-1	94032501	94032502	-	1"X17mm	12	100	-	M12	51-98	65-98	-	1,55

NEW



NEW

Chain Tensioner CHT - TGE

- Tensioner mod. T with sliding block chain tensioner in polyethylene UHMW high molecular mass (1.000.000) material Available in different colors
- Provided with bushing kit that allow the free movement of the sliding block
- Standard sintered bronze self-lubricating bushings
- On request available with stainless steel pin and springs

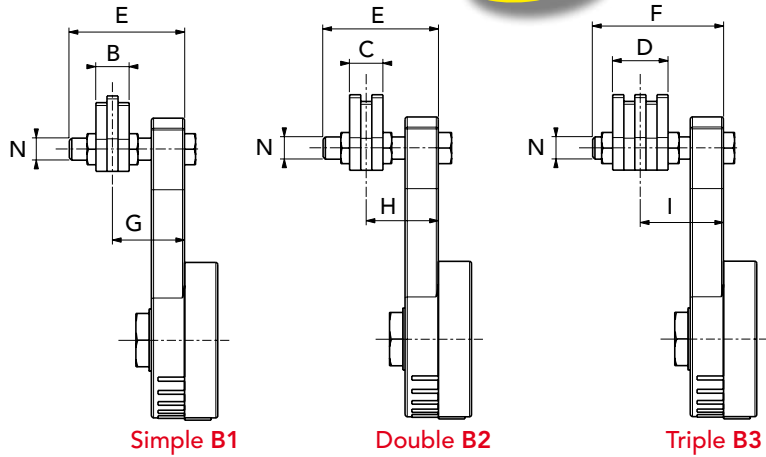

CHAIN TENSIONER CHT - TGE

TYPE	P. NUMBER SIMPLE	P. NUMBER DOUBLE	P. NUMBER TRIPLE	STEP CHAIN	B	C	D	E	F	G	H	I	N	WEIGHT Kg.
TGE1-3/8	94030901P	94030902P	94030903P	3/8"x 7/32"	20	20	25	60	80	40-58	40-58	43-75	M12	0,47
TGE1-1/2	94031201P	94031202P	94031203P	1/2"x5/16"	20	20	35	60	80	40-58	40-58	48-70	M12	0,47
TGE1-5/8	94031501P	94031502P	94031503P	5/8"x3/8"	20	25	40	80	80	40-78	43-75	50-68	M12	0,47
TGE2-5/8	94031511P	94031512P	94031513P	5/8"x3/8"	20	25	40	80	80	46-81	49-78	57-90	M12	0,76
TGE2-3/4	94031901P	94031902P	94031903P	3/4"x7/16"	20	30	49	80	100	46-81	51-76	61-86	M12	0,76
TGE2-1	94032501P	94032502P	94032503P	1"x17mm	25	45	-	100	-	46-100	59-88	-	M12	0,76

NEW



NEW
Rotating Belt Tensioner CHT-TRU

- Tensioner mod. T with chain tensioner roller RU
- Bronze self-lubricating sintered bushings
- On request available with stainless steel pin and springs

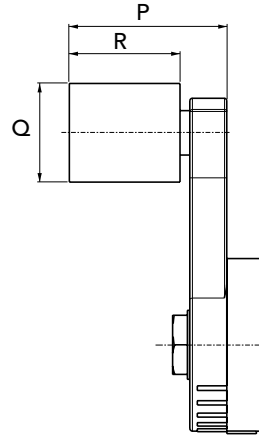

TYPE	P. NUMBER STEEL	P. NUMBER ALUMINUM	P. NUMBER POLYAMIDE	P	Q	R	WEIGHT Kg. STEEL	WEIGHT Kg. AL.	WEIGHT Kg. PA
TRU1 - 3035	94031235	94031035	94031135	53	30	35	0,51	0,45	0,43
TRU1 - 4045	94031245	94031045	94031145	66	40	45	0,70	0,57	0,53
TRU1 - 5050	94031250	94031050	94031150	67	50	50	0,97	0,65	0,59
TRU2 - 5050	94032250	94032050	94032150	70	50	50	1,22	0,90	0,84
TRU2 - 6060	94032260	94032060	94032160	80	60	60	1,69	1,06	0,94

NEW





LINEAR TENSIONERS BRAND CHT®



LINEAR TENSIONERS BRAND CHT®

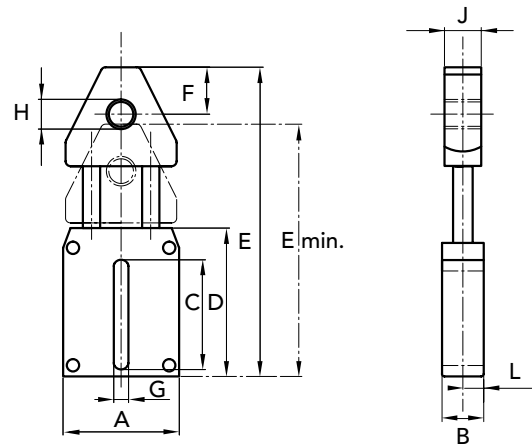

- Linear moving up to 30 mm
- Body frame in die-cast high-tensile aluminum
- Aluminum head to secure the accessories R and RU
- Steel spring and flexible items



TYPE	P. NUMBER	Newton	A	B	C	D	E	E min.	F	G	H	J	L	WEIGHT Kg.
L 1	94020001	210	60	25	56	76	146	116	15	10,5	M 12	20	12,5	0,59
L 2	94020002	300	60	25	56	76	156	126	15	12,5	M 12	20	12,5	0,61
L 3	94020003	450	60	25	56	76	166	136	15	12,5	M 12	20	12,5	0,65

On request we can supply the basic body frame in polyamide 66 FV 50.

CAD drawings available on our site
www.chiaravalli.com

Quantity, availability and prices
 on B2B Chiaravalli





- Tensioner AS with aluminum head to secure accessories
- Dry self-lubricating bushings with standard PTFE
- On request available with stainless steel pin, springs, plugs and washer

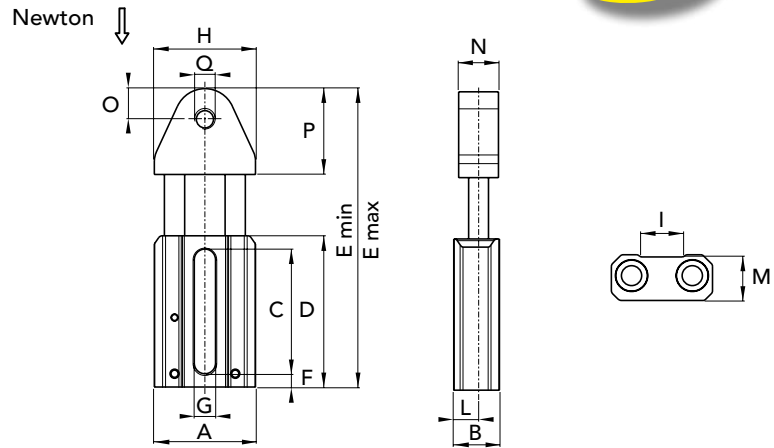

TYPE	P. NUMBER	Newton	A	B	C	D	E min	E max	F	G	H	I	L	M	N	O	P	Q	WEIGHT Kg.
AS1 M10	94021010N	240	50	23	61	74	115	143	6,5	10,5	52	20	12,5	22	20	14	40	M10	0,27
AS1 M12	94021012N	240	50	23	61	74	115	143	6,5	10,5	52	20	12,5	22	20	14	40	M12	0,26
AS1 M16	94021016N	240	50	23	61	74	115	143	6,5	10,5	52	20	12,5	22	20	14	40	M16	0,25
AS2 M12	94022012N	420	67	28	73	87	138	175	7	12,5	67	25	15	25,5	25	12	50	M12	0,52
AS2 M16	94022016N	420	67	28	73	87	138	175	7	12,5	67	25	15	25,5	25	12	50	M16	0,51
AS3 M12	94023012N	650	80	32,5	88	104	165	207	8	14,5	80	29,5	17,5	28,5	30	14	60	M12	0,89
AS3 M14	94023014N	650	80	32,5	88	104	165	207	8	14,5	80	29,5	17,5	28,5	30	14	60	M14	0,88
AS3 M16	94023016N	650	80	32,5	88	104	165	207	8	14,5	80	29,5	17,5	28,5	30	14	60	M16	0,88





CHIARAVALLI GROUP BRAND CHT® LINEAR CHAIN TENSIONER CHT - ASR CHT - ASTN

NEW

LINEAR CHAIN TENSIONER CHT - ASR CHT - ASTN

- Tensioner AS with chain tensioner sprockets TN or R
- Dry self-lubricating bushings with standard PTFE
- On request available with stainless steel pins, springs, plugs and washers

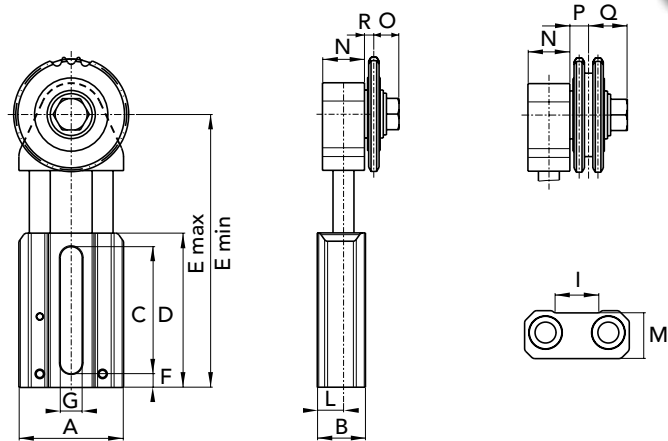

TYPE	P. NUMBER SIMPLE	P. NUMBER DOUBLE	Newton	Step chain	TEETH	A	B	C	D	E min	E max	F	G	I	L	M	N	O	P	Q	R	WEIGHT Kg.
ASR1-3/8"15	94021091	94021092	240	3/8x7/32"	15	50	23	61	74	101	129	6,5	10,5	20	12,5	22	20	11,5	11,7	16,5	6,5	0,45
ASR1-1/2"15	94021121	94021122	240	1/2"x5/16"	15	50	23	61	74	101	129	6,5	10,5	20	12,5	22	20	12,5	14,4	19,4	7,5	0,50
ASR1-5/8"15	94021151	94021152	240	5/8"x3/8"	15	50	23	61	74	101	129	6,5	10,5	20	12,5	22	20	12,5	15,8	20,8	7,5	0,70
ASR2-5/8"15	94022151	94022152	420	5/8"x3/8"	15	67	28	73	87	128	164	7	12,5	25	15	25,5	25	12,5	15,8	20,8	7,5	0,95
ASR2-3/4"15	94022191	94022192	420	3/4"x7/16"	15	67	28	73	87	128	164	7	12,5	25	15	25,5	25	13,5	18,2	23,2	8,5	1,15
ASR3-1"12	94023251	94023252	650	1"x17 mm	12	80	32,5	88	104	154	195	8	14,5	29,5	17,5	28,5	30	16,2	26,8	31,7	11	1,75
ASTN1-3/8"21	940210921	-	240	3/8x7/32"	21	50	23	61	74	101	129	6,5	10,5	20	12,5	22	20	19,7	-	-	9,2	0,47
ASTN1-1/2"16	940211216	-	240	1/2"x5/16"	16	50	23	61	74	101	129	6,5	10,5	20	12,5	22	20	19,7	-	-	9,2	0,49
ASTN1-5/8"17	940211517	-	240	5/8"x3/8"	17	50	23	61	74	101	129	6,5	10,5	20	12,5	22	20	19,7	-	-	9,2	0,68
ASTN2-5/8"17	940221517	-	420	5/8"x3/8"	17	67	28	73	87	128	164	7	12,5	25	15	25,5	25	19,7	-	-	9,2	1,04

NEW



CAD drawings available on our site
www.chiaravalli.com

Quantity, availability and prices
on B2B Chiaravalli



NEW

- AS tensioner with roller belt-tensioner RU
- Dry self-lubricating bushings in standard PTFE
- On request available with stainless steel pins, springs, plugs and washers

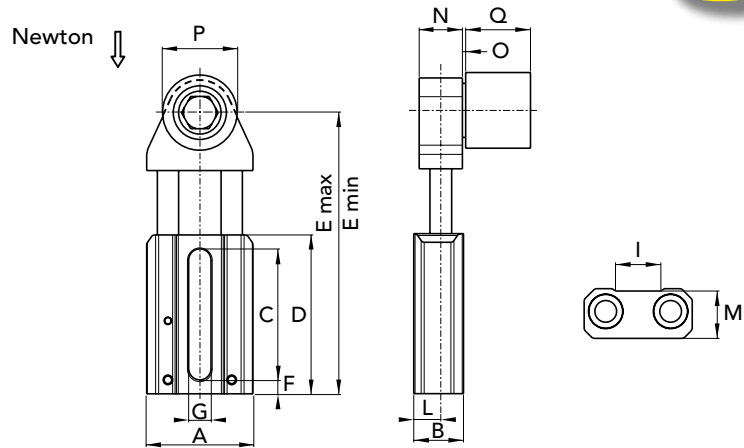

TYPE	P. NUMBER ALUMINUM	P. NUMBER STEEL	P. NUMBER POLYAMIDE	Newton	A	B	C	D	E min	E max	F	G	I	L	M	N	O	P	Q
ASRU1-3035	94021035	94021235	94021135	240	50	23	61	74	101	129	6,5	10,5	20	12,5	22	20	2,5	30	35
ASRU1-4045	94021045	94021245	94021145	240	50	23	61	74	101	129	6,5	10,5	20	12,5	22	20	2,5	40	45
ASRU1-5050	94021050	94021250	94021150	240	50	23	61	74	101	129	6,5	10,5	20	12,5	22	20	2,5	50	50
ASRU2-5050	94022050	94022250	94022150	420	67	28	73	87	128	164	7	12,5	25	15	25,5	25	2,5	50	50
ASRU3-5050	94023050	94023250	94023150	650	67	28	73	87	154	195	8	14,5	29,5	17,5	28,5	30	2,5	50	50
ASRU3-6060	94023060	94023260	94023150	650	80	32,5	88	104	154	195	8	14,5	29,5	17,5	28,5	30	2,5	60	60

TYPE	WEIGHT kg. ALUMINUM	WEIGHT kg. STEEL	WEIGHT kg. POLYAMIDE
ASRU1-3035	0,35	0,40	0,32
ASRU1-4045	0,46	0,59	0,43
ASRU1-5050	0,55	0,86	0,50
ASRU2-5050	0,81	1,13	0,76
ASRU3-5050	1,18	1,48	1,11
ASRU3-6060	1,34	1,95	1,22

NEW



ROLLER MATERIAL: POLYAMIDE (PA)
ALUMINUM (AL)
GALVANIZED STEEL (GS)

CAD drawings available on our site
www.chiaravalli.com

Quantity, availability and prices
on B2B Chiaravalli

LINEAR BELT TENSIONER CHT - ASRU



- Tensioner component CHT-LP with sliding block in polyethylene high molecular mass secured on body frame pins
- Sliding block available on request in different colors

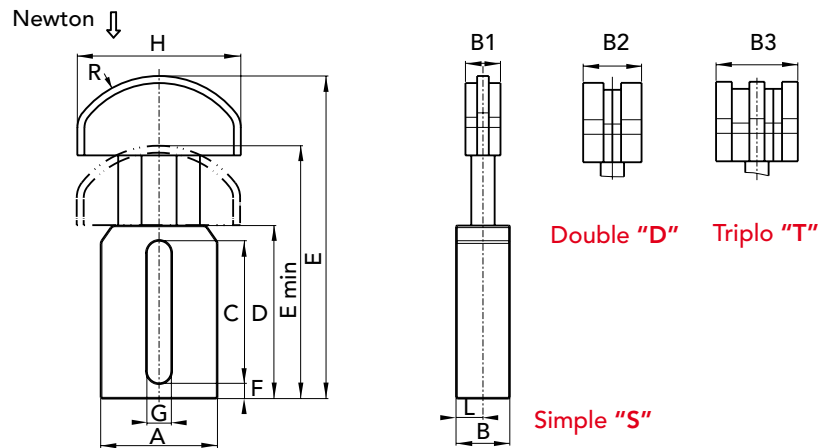

TYPE	P. NUMBER SIMPLE	P. NUMBER DOUBLE	P. NUMBER TRIPLE	Step Chain	Newton	A	B	C	D	E	E min	F	G	H	L	B1	B2	B3	R	WEIGHT Kg.
LP 1	94010901	94010902	94010903	3/8"	210	60	25	56	76	140	110	4	10,5	70	12,5	20	20	25	42	0,57
LP 1	94011201	94011202	94011203	1/2"	210	60	25	56	76	140	110	4	10,5	70	12,5	20	20	35	42	0,57
LP 2	94011501	94011502	94011503	5/8"	300	60	25	56	76	145	115	4	12,5	85	12,5	20	25	40	50	0,58
LP 2	94011901	94011902	94011903	3/4"	300	60	25	56	76	145	115	4	12,5	85	12,5	20	30	49	50	0,58
LP 3	94012501	94012502	94012503	1"	450	60	25	56	76	150	120	4	12,5	100	12,5	20	45	78	58	0,60
LP 3	94013101	94013102	94013103	1" 1/4	450	60	25	56	76	150	120	4	12,5	100	12,5	20	54	90	58	0,60
LP 3	94013801	94013802	94013803	1" 1/2	450	60	25	56	76	150	120	4	12,5	100	12,5	20	70	119	58	0,60

The basic structure in
POLYAMIDE 66 FV 50
 is supplied on request





- Tensioner AS with sliding block chain tensioner in polyethylene UHMW high molecular mass (1.000.000) material
- Available on request in different colors
- Elliptical profile to increase contact surface
- Dry self-lubricating bushings in standard PTFE
- On request available with stainless steel pins, springs, plugs and washers

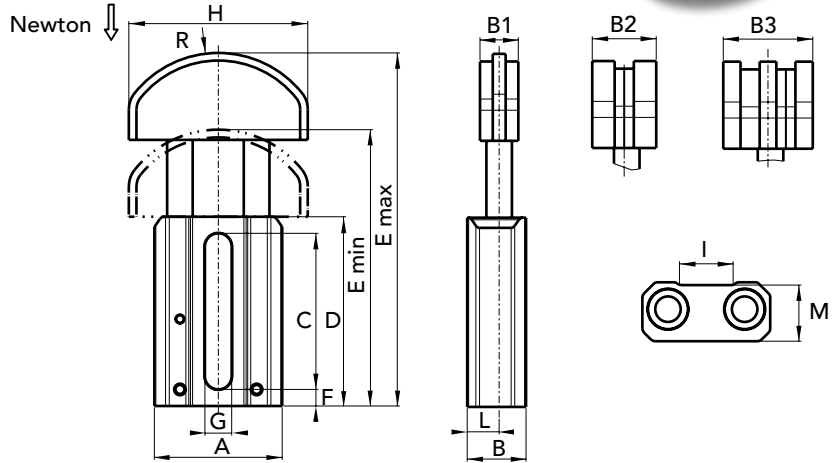

TYPE	P. NUMBER SIMPLE	P. NUMBER DOUBLE	P. NUMBER TRIPLE	Newton	Step Chain	A	B	B1	B2	B3	C	D	E		F	G	H	I	L	M	R	WEIGHT Kg.
													min	max								
ASGE1 - 3/8"	94000901N	94000902N	94000903N	240	3/8x7/32"	50	23	20	20	26	61	74	110	138	6,5	10,5	68	20	12,5	22	42	0,24
ASGE1 - 1/2"	94001201N	94001202N	94001203N	240	1/2"x5/16"	50	23	20	20	34,5	61	74	110	138	6,5	10,5	68	20	12,5	22	42	0,24
ASGE1 - 5/8"	94001501N	94001502N	94001503N	240	5/8"x3/8"	50	23	20	25	41,5	61	74	110	138	6,5	10,5	68	20	12,5	22	42	0,24
ASGE2 - 5/8"	94001511N	94001512N	94001513N	420	5/8"x3/8"	67	28	20	25	41,5	73	87	133	170	7	12,5	88	25	15	25,5	54	0,44
ASGE2 - 3/4"	94001911N	94001912N	94001913N	420	3/4"x7/16"	67	28	20	30	49	73	87	133	170	7	12,5	88	25	15	25,5	54	0,45
ASGE2 - 1"	94002501N	94002502N	-	420	1"x17 mm	67	28	25	45	-	73	87	133	170	7	12,5	88	25	15	25,5	54	0,46
ASGE3 - 1"	94002511N	94002512N	94002513N	650	1"x17 mm	80	32,5	25	45	78	88	104	160	202	8	14,5	108	29,5	17,5	28,5	66	0,75
ASGE3 - 1"1/4	94003101N	94003102N	94003103N	650	1"1/4x3/4"	80	32,5	25	54	90	88	104	160	202	8	14,5	108	29,5	17,5	28,5	66	0,75
ASGE3 - 1"1/2	94003801N	94003802N	94003803N	650	1"1/2x1"	80	32,5	25	71	119	88	104	160	202	8	14,5	108	29,5	17,5	28,5	66	0,75
ASGE3 - 1"3/4	94004401N	-	-	650	1"3/4x1"1/4	80	32,5	30	-	-	88	104	160	202	8	14,5	108	29,5	17,5	28,5	66	0,80
ASGE3 - 2"	94005001N	-	-	650	2"x1"1/4	80	32,5	30	-	-	88	104	160	202	8	14,5	108	29,5	17,5	28,5	66	0,80



NEW

- Tensioner AS with sliding block chain tensioner polyethylene UHMW high molecular mass (1.000.000) material
- Available on request in different colors
- Sliding block with semicircle profile
- Dry self-lubricating bushings with standard PTFE
- On request available with stainless steel pin, springs, plugs and washer

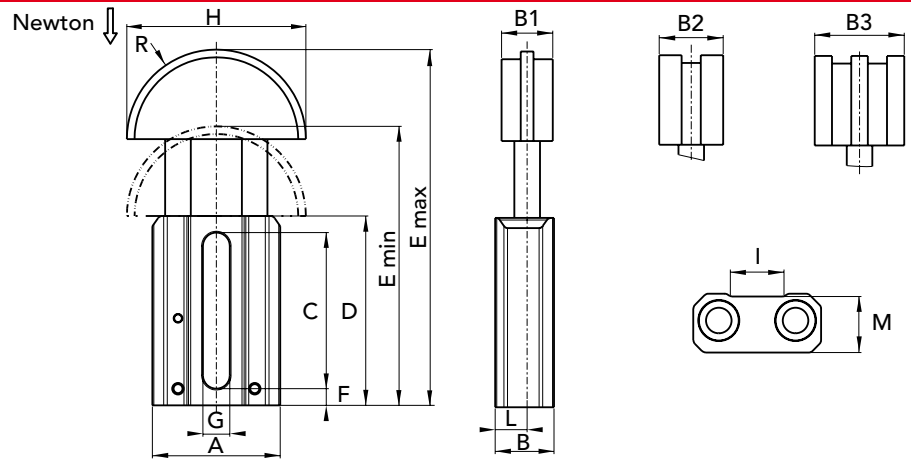

TYPE	P. NUMBER SIMPLE	P. NUMBER DOUBLE	P. NUMBER TRIPLI	Newton	Step Chain	A	B	B1	B2	B3	C	D	E	E	F	G	H	I	L	M	R	WEIGHT Kg.
													min	max								
ASGO1 - 3/8"	94100901N	94100902N	94100903N	240	3/8x7/32"	50	23	20	20	26	61	74	110	138	6,5	10,5	70	20	12,5	22	35	0,24
ASGO1 - 1/2"	94101201N	94101202N	94101203N	240	1/2"x5/16"	50	23	20	20	34,5	61	74	110	138	6,5	10,5	70	20	12,5	22	35	0,24
ASGO1 - 5/8"	94101501N	94101502N	94101503N	240	5/8"x3/8"	50	23	20	25	41,5	61	74	110	138	6,5	10,5	70	20	12,5	22	35	0,24
ASGO2 - 5/8"	94101511N	94101512N	94101513N	420	5/8"x3/8"	67	28	20	25	41,5	73	87	133	170	7	12,5	90	25	15	25,5	45	0,42
ASGO2 - 3/4"	94101901N	94101902N	94101903N	420	3/4"x7/16"	67	28	20	30	49	73	87	133	170	7	12,5	90	25	15	25,5	45	0,42
ASGO2 - 1"	94102501N	94102502N	94102503N	420	1"x17 mm	67	28	25	45	-	73	87	133	170	7	12,5	90	25	15	25,5	45	0,42
ASGO3 - 1"	94102511N	94102512N	94102513N	650	1"x17 mm	80	32,5	25	45	78	88	104	160	202	8	14,5	110	29,5	17,5	28,5	55	0,74
ASGO3 - 1"1/4	94103101N	94103102N	94103103N	650	1"1/4x3/4"	80	32,5	25	54	90	88	104	160	202	8	14,5	110	29,5	17,5	28,5	55	0,74
ASGO3 - 1"1/2	94103801N	94103802N	94103803N	650	1"1/2x1"	80	32,5	25	71	119	88	104	160	202	8	14,5	110	29,5	17,5	28,5	55	0,74
ASGO3 - 1"3/4	94104401N	-	-	650	1"3/4x1"1/4	80	32,5	30	-	-	88	104	160	202	8	14,5	110	29,5	17,5	28,5	55	0,79
ASGO3 - 2"	94105001N	-	-	650	2"x1"1/4	80	32,5	30	-	-	88	104	160	202	8	14,5	110	29,5	17,5	28,5	55	0,79

NEW



NEW

- Tensioner T with sliding block chain tensioner polyethylene UHMW high molecular mass (1.000.000) material Available in different colors
- Arch profile for long chain sections
- Dry self-lubricating bushings with standard PTFE
- On request available with stainless steel pins, springs, plugs and washers

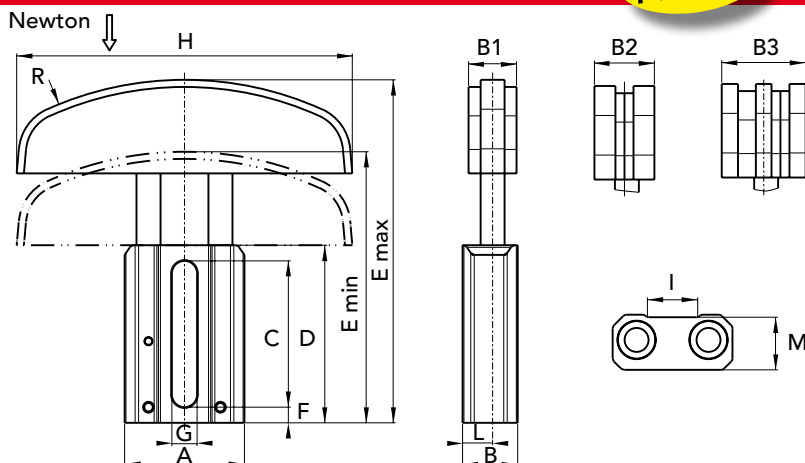

TYPE	P. NUMBER SIMPLE	P. NUMBER DOUBLE	P. NUMBER TRIPLI	Newton	Step Chain	A	B	B1	B2	B3	C	D	E		F	G	H	I	L	M	R	WEIGHT Kg.
													min	max								
ASGA1 - 3/8"	94200901N	94200902N	94200903N	240	3/8x7/32"	50	23	20	20	26	61	74	115	143	6,5	10,5	140	20	12,5	22	120	0,26
ASGA1 - 1/2"	94201201N	94201202N	94201203N	240	1/2"x5/16"	50	23	20	20	34,5	61	74	115	143	6,5	10,5	140	20	12,5	22	120	0,26
ASGA1 - 5/8"	94201501N	94201502N	94201503N	240	5/8"x3/8"	50	23	20	25	41,5	61	74	115	143	6,5	10,5	140	20	12,5	22	120	0,26
ASGA2 - 5/8"	94201511N	94201512N	94201513N	420	5/8"x3/8"	67	28	20	25	41,5	73	87	128	164	7	12,5	140	25	15	25,5	140	0,48
ASGA2 - 3/4"	94201901N	94201902N	94201903N	420	3/4"xx7/16"	67	28	20	30	49	73	87	128	164	7	12,5	140	25	15	25,5	140	0,50
ASGA3 - 1"	94202511N	94202512N	94202513N	650	1"x17 mm	80	32,5	25	45	78	88	104	145	187	8	14,5	140	29,5	17,5	28,5	160	0,74
ASGA3 - 1"1/4	94203101N	94203102N	94203103N	650	1"1/4x3/4"	80	32,5	25	54	90	88	104	145	187	8	14,5	140	29,5	17,5	28,5	160	0,74
ASGA3 - 1"1/2	94203801N	94203802N	94203803N	650	1"1/2x1"	80	32,5	25	71	119	88	104	145	187	8	14,5	140	29,5	17,5	28,5	160	0,74
ASGA3 - 1"3/4	94204401N	-	-	650	1"3/4x1"1/4	80	32,5	30	-	-	88	104	145	187	8	14,5	140	29,5	17,5	28,5	160	0,79
ASGA3 - 2"	94205001N	-	-	650	2"x1"1/4	80	32,5	30	-	-	88	104	145	187	8	14,5	140	29,5	17,5	28,5	160	0,79

LINEAR CHAIN TENSIONER CHT - ASGA

NEW





ROTATING TENSIONER BRAND CHT®



ROTATING TENSIONER BRAND CHT®



SERIES E

- 1) Loosen the fixing screw "A" slightly with the first spanner.
- 2) Rotate the tensioner "B" in the desired direction with a second spanner, placed on basic body square
- 3) Tighten the screw "A".

NOTE

In case of irregular surfaces or heavy applications, it is advisable to use two securing screws, to avoid the tensioner rotation.

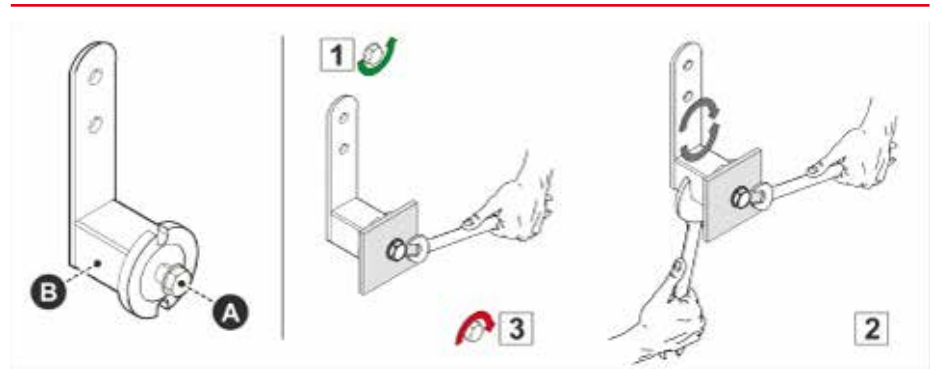

NEW

- Tensioner E with two holes for accessories fixing
- Flexible rubber items
- On request available a stainless steel version

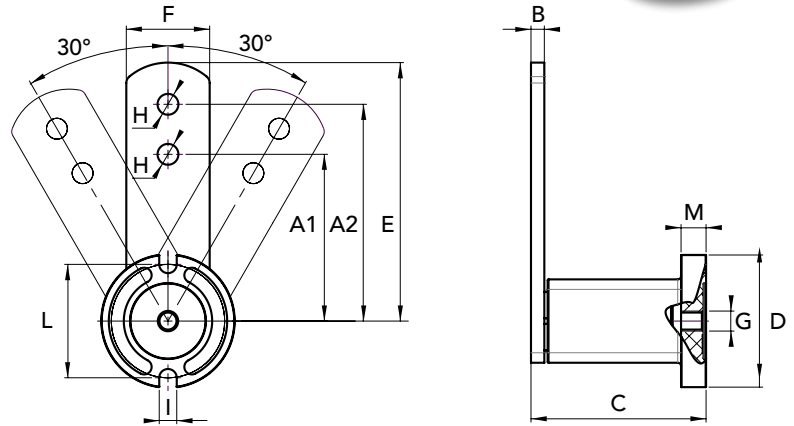

TYPE	P. NUMBER	Newton A2	Newton A1	A1	A2	B	C	D	E	F	G	H	I	L	M	WEIGHT Kg.
E 1	94070001	0 - 90	0 - 110	60	80	5	50	35	90	20	M6	8,5	7	31	6	0,18
E 2	94070002	0 - 130	0 - 160	80	100	5	63	45	112,5	30	M8	10,5	9	41	8	0,35
E 3	94070003	0 - 330	0 - 410	80	100	6	77	59	115	35	M10	10,5	9	48	10	0,60
E 4	94070004	0 - 800	0 - 1000	100	130	8	107	79	155	50	M12	12,5	11	63	15	1,90
E 5	94070005	0 - 1500	0 - 1850	140	175	10	139	98	205	60	M16	20,5	13	84	15	3,80
E 6	94070006	0 - 2500	0 - 3100	180	225	12	199	118	260	70	M20	20,5	13	100	18	6,50
E 7	94070007	0 - 3800	0 - 4800	200	250	20	210	128	290	80	M24	20,5	17	107	20	9,00

NEW



NEW

- Tensioner E with chain tensioner sprocket R (simple, double, triple)
- Flexible rubber items
- On request available a stainless steel version

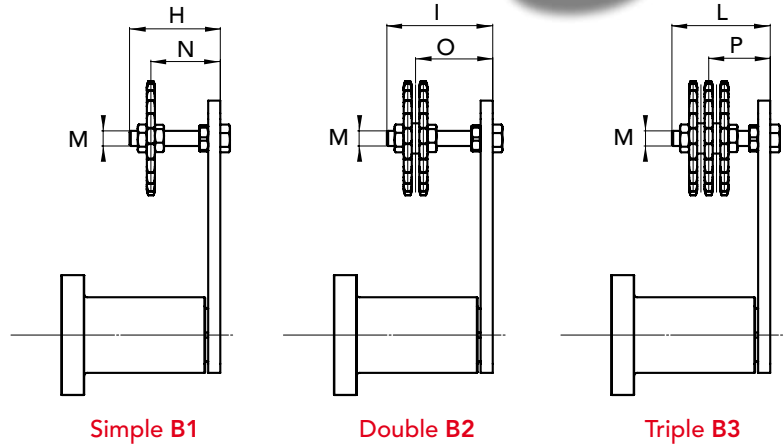

Simple B1

Double B2

Triple B3

TYPE	P. NUMBER SIMPLE	P. NUMBER DOUBLE	P. NUMBER TRIPLE	Step Chain	H	I	L	M	N	O	P	WEIGHT Kg.
ER 2 - 3/8	94070921	94070922	-	3/8x7/32"	55	55	-	M10	22-43	27-39	-	0,48
ER 3 - 3/8	94070931	94070932	94070933	3/8x7/32"	55	60	70	M10	23-43	28-39	33-48	0,73
ER 3 - 1/2	94071231	94071232	-	1/2"x5/16"	55	60	-	M10	23-44	30-37	-	0,81
ER 4 - 1/2	-	-	94071243	1/2"x5/16"	-	-	80	M12	-	-	41-51	2,50
ER 4 - 5/8	94071541	94071542	94071543	5/8"x3/8"	80	80	80	M12	27-65	36-57	43-50	2,28
ER 4 - 3/4	94071941	94071942	-	3/4"x7/16"	80	80	-	M12	27-65	37-56	-	2,46
ER 5 - 5/8	-	-	94071553	5/8"x3/8"	-	-	120	M20	-	-	56-84	5,00
ER 5 - 3/4	94071951	94071952	94071953	3/4"x7/16"	100	120	120	M20	40-80	50-90	59-80	4,61
ER 5 - 1	94072551	94072552	-	1"x17 mm	100	120	-	M20	40-80	55-84	-	5,43
ER 6 - 1	-	-	94072563	1"x17 mm	-	-	160	M20	-	-	74-108	9,50
ER 6 - 1 1/4	94073161	94073162	94073163	1"1/4x3/4"	100	140	160	M20	40-80	60-120	78-105	9,28
ER 6 - 1 1/2	94073861	94073862	94073863	1"1/2x1"	140	140	180	M20	40-120	65-97	90-111	9,33

ROTATION TENSIONER CHT - ER

NEW





- Tensioner E with belt tensioner roller RU
- Flexible rubber items
- On request available a stainless steel version

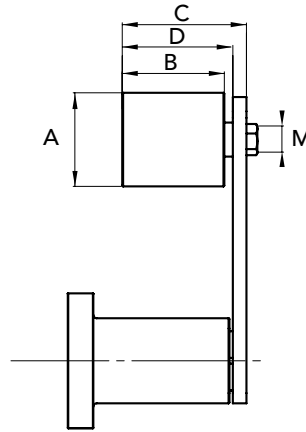

TYPE	P. NUMBER ALUMINUM	P. NUMBER STEEL	P. NUMBER POLYAMIDE	A	B	C	D	M	WEIGHT Kg. ALUMINUM	WEIGHT Kg. STEEL	WEIGHT Kg. PA
ERU 1 - 3035	94073501	94073521	94073511	30	35	51	43	M8	0,27	0,33	0,25
ERU 2 - 4045	94074502	94074522	94074512	40	45	67	56	M10	0,57	0,68	0,53
ERU 2 - 5050	94075002	94075022	94075012	50	50	69	58	M12	0,64	0,95	0,58
ERU 3 - 4045	94074503	94074523	94074513	40	45	67	57	M10	0,82	0,93	0,78
ERU 3 - 5050	94075003	94075023	94075013	50	50	69	59	M12	0,89	1,20	0,83
ERU 4 - 6060	94076004	94076024	94076014	60	60	89	76	M12	2,35	2,98	2,24
ERU 5 - 8080	94078005	94078025	94078015	80	90	127	109	M20	4,90	6,50	4,40
ERU 6 - 8090	-	-	94079016	90	135	169	154	M20	-	-	7,60

NEW

ROLLER MATERIAL: POLYAMIDE (PA)
ALUMINUM (AL)
GALVANIZED STEEL (GS)



NEW

- Tensioner E with sliding block chain tensioner in polyethylene UHMW high molecular mass (1.000.000) material
- Available in different colors
- Provided with bushing kit allowing the free movement of the sliding block
- Flexible rubber items

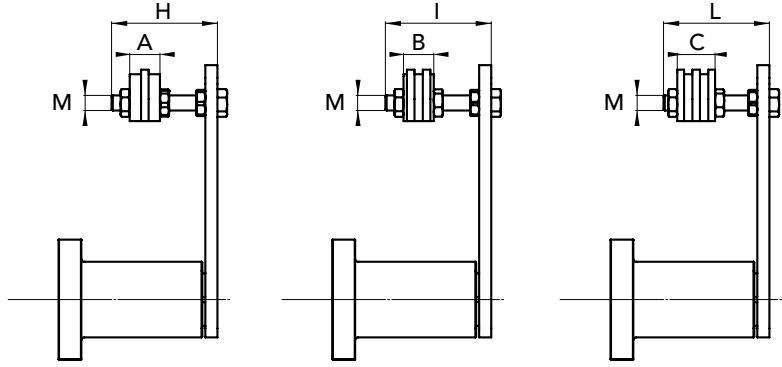

Simple B1

Double B2

Triple B3

TYPE	P. NUMBER SIMPLE	P. NUMBER DOUBLE	P. NUMBER TRIPLE	Step Chain	A	B	C	H	I	L	M	WEIGHT Kg.
EGE 1 - 3/8	94070901	94070902	-	3/8 X 7/32"	20	20	-	45	45	-	M8	0,30
EGE 2 - 3/8	-	-	94070903	3/8 X 7/32"	-	-	25	-	-	45	M10	0,50
EGE 2 - 1/2	94071201	94071202	-	1/2" X 5/16"	20	20	-	55	55	-	M10	0,50
EGE 3 - 1/2	94071211	94071212	94071213	1/2" X 5/16"	20	20	35	55	60	70	M10	0,75
EGE 3 - 5/8	94071501	94071502	-	5/8" X 3/8"	20	25	-	55	70	-	M10	0,78
EGE 3 - 3/4	94071901	94071902	-	3/4" X 7/16"	20	30	-	60	70	-	M10	0,80
EGE 4 - 5/8	-	-	94071503	5/8" X 3/8"	-	-	40	-	-	100	M12	2,10
EGE 4 - 3/4	94071911	94071912	94071913	3/4" X 7/16"	20	30	49	80	80	100	M12	2,10
EGE 4 - 1	94072501	94072502	94072503	1" X 17 mm	20	45	78	80	90	100	M12	2,20
EGE 5 - 1	-	94072512	94072513	1" X 17 mm	-	45	78	-	100	120	M20	4,00
EGE 5 - 1 1/4	94073101	94073102	94073103	1"1/4 x 3/4"	20	54	90	100	120	130	M20	4,20
EGE 5 - 1 1/2	94073801	94073802	94073803	1"1/2 x 1"	20	71	119	100	120	130	M20	4,20

ROTATION CHAIN TENSIONER CHT - EGE

NEW



NEW

- Belt tensioner roller complete of screws and bearings
- Made of aluminum, galvanized steel or in plastic material

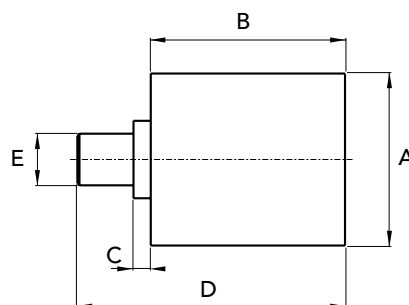

TYPE	P. NUMBER STEEL	P. NUMBER ALUMINUM	P. NUMBER POLYAMIDE	A	B	C	D	E	WEIGHT Kg. STEEL	WEIGHT Kg. ALUMINUM	WEIGHT Kg. PA
RU 3035	94040235	94040035	94040135	30	35	2	51	M8	0,15	0,09	0,07
RU 4045	94040245	94040045	94040145	40	45	6	67	M10	0,33	0,22	0,18
RU 5050	94040250	94040050	94040150	50	50	2,5	70	M12	0,60	0,29	0,23
RU 6060	94040260	94040060	-	60	60	2,5	80	M12	1,08	0,45	-
RU 6060	-	-	94040160	60	60	8	85	M12	-	-	0,34
RU 8080	94040280	94040080	94040180	80	80	2,5	100	M12	2,70	1,10	0,60
RU 8090	-	-	94040190	80	90	8,5	125	M20	-	-	1,10
RU 90135	-	-	94040135	90	135	8,5	170	M20	-	-	1,70

NEW



- Tensioner accessory CHT-P with free sliding block of polyethylene high molecular mass material.
Available in different colors

- 1 Simple "P1"
- 2 Double "P2"
- 3 Triple "P3"

Esempio di applicazione pattino CHT - P
con tenditore rotante TYPE CHT - T

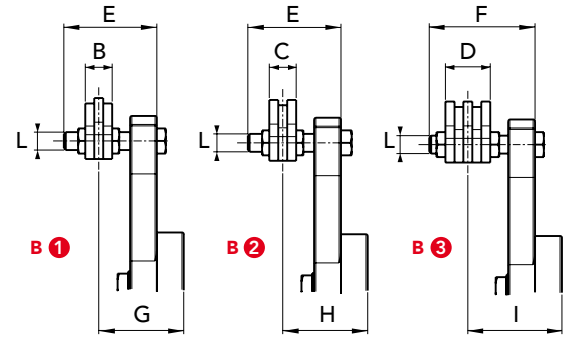
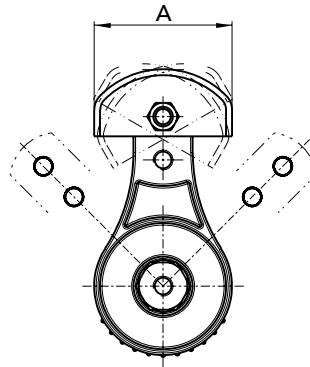

Esempio di applicazione con supporto TYPE CHT

TYPE	P. NUMBER SIMPLE	P. NUMBER DOUBLE	P. NUMBER TRIPLE	Step Chain	A	B	C	D	E	F	G	H	I	L	WEIGHT Kg.
P 1	94050901	-	-	3/8"	70	20	-	-	60	-	40-58	-	-	M12	0,10
P 1	94051201	-	-	1/2"	70	20	-	-	60	-	40-58	-	-	M12	0,11
P 1	94051501	-	-	5/8"	85	20	-	-	80	-	40-78	-	-	M12	0,17
P 1	94051901	-	-	3/4"	85	20	-	-	80	-	46-81	-	-	M12	0,19
P 1	94052501	-	-	1"	100	20	-	-	100	-	46-100	-	-	M12	0,28
P 2	-	94050902	-	3/8"	70	-	20	-	60	-	-	40-58	-	M12	0,11
P 2	-	94051202	-	1/2"	70	-	20	-	60	-	-	40-58	-	M12	0,11
P 2	-	94051502	-	5/8"	85	-	25	-	80	-	-	43-75	-	M12	0,17
P 2	-	94051902	-	3/4"	85	-	30	-	80	-	-	51-76	-	M12	0,21
P 2	-	94052502	-	1"	100	-	45	-	100	-	-	59-88	-	M12	0,32
P 3	-	-	94050903	3/8"	70	-	-	25	-	80	-	-	43-75	M12	0,15
P 3	-	-	94051203	1/2"	70	-	-	35	-	80	-	-	48-70	M12	0,18
P 3	-	-	94051503	5/8"	85	-	-	40	-	80	-	-	50-68	M12	0,26
P 3	-	-	94051903	3/4"	85	-	-	49	-	100	-	-	61-86	M12	0,35





NEW

- Chain tensioner sliding block of polyethylene UHMW high molecular mass (1.000.000) material
- Complete with a bushing kit, allow any free movement of the sliding block

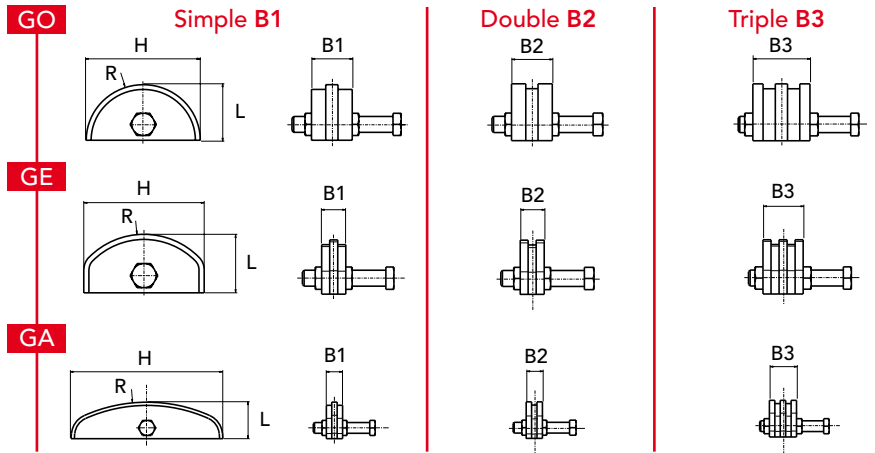

TYPE	P. NUMBER SIMPLE	P. NUMBER DOUBLE	P. NUMBER TRIPLE	Step Chain	B1	B2	B3	L	H	R	WEIGHT Kg.
GA - 3/8"	94080901	94080902	94080903	3/8" x 7/32"	20	20	26	40	140	120	0,16
GA - 1/2"	94081201	94081202	94081203	1/2" x 5/16"	20	20	34,5	40	140	120	0,16
GA - 5/8"	94081501	94081502	94081503	5/8" x 3/8"	20	25	41,5	40	140	140	0,23
GA - 3/4"	94081901	94081902	94081903	3/4" x 7/16"	20	30	49	40	140	140	0,23
GA - 1"	94082501	94082502	94082503	1" x 17 mm	25	45	78	40	140	160	0,30
GA - 1"1/4	94083101	94083102	94083103	1"1/4 x 3/4"	25	54	90	40	140	160	0,30
GA - 1"1/2	94083801	94083802	94083803	1"1/2 x 1"	25	71	119	40	140	160	0,30
GE - 3/8"	94090901	94090902	94090903	3/8" x 7/32"	20	20	26	35	68	42	0,10
GE - 1/2"	94091201	94091202	94091203	1/2" x 5/16"	20	20	34,5	35	68	42	0,11
GE - 5/8"	94091501	94091502	94091503	5/8" x 3/8"	20	25	41,5	45	88	54	0,17
GE - 3/4"	94091901	94091902	94091903	3/4" x 7/16"	20	30	49	45	88	54	0,19
GE - 1"	94092501	94092502	94092503	1" x 17 mm	25	45	78	55	108	66	0,28
GE - 1"1/4	94093101	94093102	94093103	1"1/4 x 3/4"	25	54	90	55	108	66	0,28
GE - 1"1/2	94093801	94093802	94093803	1"1/2 x 1"	25	71	119	55	108	66	0,28
GO - 3/8"	94110901	94110902	94110903	3/8" x 7/32"	20	20	26	35	70	35	0,10
GO - 1/2"	94111201	94111202	94111203	1/2" x 5/16"	20	20	34,5	35	70	35	0,11
GO - 5/8"	94111501	94111502	94111503	5/8" x 3/8"	20	25	41,5	45	90	45	0,17
GO - 3/4"	94111901	94111902	94111903	3/4" x 7/16"	20	30	49	45	90	45	0,19
GO - 1"	94112501	94112502	94112503	1" xs 17 mm	25	45	78	55	110	55	0,28
GO - 1"1/4	94113101	94113102	94113103	1"1/4 x 3/4"	25	54	90	55	110	55	0,28
GO - 1"1/2	94113801	94113802	94113803	1"1/2 x 1"	25	71	119	55	110	55	0,28

NEW



GO



GE



GA

CAD drawings available on our site
www.chiaravalli.com

Quantity, availability and prices
 on B2B Chiaravalli



- Zinc-coated chain tensioner sprockets complete with self-lubricating ball-bearings 2Z and accessories for the assembling on tensioners CHT-L, CHT-T, CHT-AS and CHT-E.

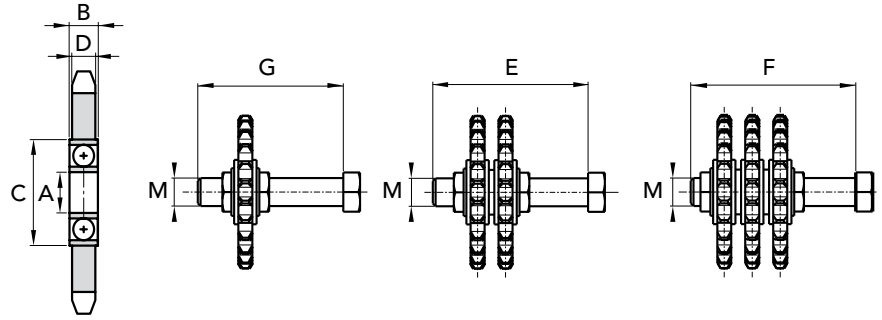

TYPE	P. NUMBER SIMPLE	P. NUMBER DOUBLE	P. NUMBER TRIPLI	Step Chain	Z Teeth	A	B	C	D h14	M	G	E	F
R	94060911	94060912	-	3/8"	15	10	8	26	5,3	M10	55	55	-
R	94060901	94060902	94060903	3/8"	15	12	8	28	5,3	M12	60	60	80
R	94061201	94061202	94061203	1/2"	15	12	10	32	7,2	M12	60	60	80
R	94061211	94061212	-	1/2"	15	10	9	30	7,2	M10	55	60	-
R	94061501	94061502	94061503	5/8"	15	12	10	32	9,1	M12	80	80	80
R	-	-	94061523	5/8"	15	20	12	42	9,1	M20	-	-	120
R	94061901	94061902	94061903	3/4"	15	12	12	37	11,1	M12	80	80	100
R	94061921	94061922	94061923	3/4"	15	20	14	47	11,1	M20	100	120	120
R	94062501	94062502	-	1"	12	12	12	37	16,2	M12	100	100	-
R	94062521	94062522	94062523	1"	12	20	15	47	16,2	M20	100	120	160
R	94063121	94063122	94063123	1"1/4	13	20	15	52	18,5	M20	100	140	160
R	94063821	94063822	94063823	1"1/2	11	20	15	52	24,1	M20	140	140	180

TYPE	P. NUMBER SIMPLE	WEIGHT Kg. SIMPLE	P. NUMBER DOUBLE	WEIGHT Kg. DOUBLE	P. NUMBER TRIPLE	WEIGHT Kg. TRIPLE
R	94060911	0,15	94060912	0,23	-	-
R	94060901	0,13	94060902	0,21	94060903	0,26
R	94061201	0,18	94061202	0,35	94061203	0,50
R	94061211	0,20	94061212	0,37	-	-
R	94061501	0,35	94061502	0,60	94061503	0,95
R	-	-	-	-	94061523	1,30
R	94061901	0,55	94061902	1,00	94061903	1,40
R	94061921	0,85	94061922	1,35	94061923	1,60
R	94062501	0,90	94062502	1,70	-	2,50
R	94062521	1,00	94062522	1,90	94062523	2,70
R	94063121	2,00	94063122	3,60	94063123	5,20
R	94063821	2,35	94063822	4,00	94063823	5,80





With NATIONAL BEARINGS

Our chain tensioner are complete of bearings, ready to be assembled in particular tension positions.

The accurate machining and the particular assembly realized with a ball bearing with a double protection screen, allow an application with greater load and more wear resistance.

The central bearing with "widen" ring, allow an easy assembly on special machines of all kinds of machinery.

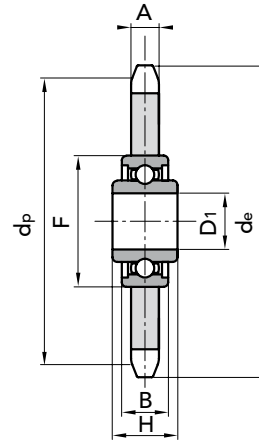

Z	STEP	d _e	d _p	P. NUMBER	A	D1	F	B	H	kg.
23	8 x 3	62,15	58,75	30008023	2,8	16 $\pm 0,26$	40	12	18,3	0,13
21	3/8" x 7/32"	68,00	63,90	30009021	5,3	16 $\pm 0,26$	40	12	18,3	0,15
22	3/8" x 7/32"	71,00	66,93	30009022	5,3	16 $\pm 0,26$	40	12	18,3	0,16
18	1/2" x 1/8"	78,90	73,14	30010018	3,0	16 $\pm 0,26$	40	12	18,3	0,18
15	1/2" x 3/16"	66,80	61,09	30011015	4,5	16 $\pm 0,26$	40	12	18,3	0,16
16	1/2" x 3/16"	70,90	65,10	30011016	4,5	16 $\pm 0,26$	40	12	18,3	0,17
18	1/2" x 3/16"	78,90	73,13	30011018	4,5	16 $\pm 0,26$	40	12	18,3	0,20
14	1/2" x 5/16"	61,80	57,07	30012014	7,2	16 $\pm 0,26$	40	12	18,3	0,13
16	1/2" x 5/16"	69,50	65,10	30012016	7,2	16 $\pm 0,26$	40	12	18,3	0,17
18	1/2" x 5/16"	77,80	73,14	30012018	7,2	16 $\pm 0,26$	40	12	18,3	0,22
14	5/8" x 3/8"	78,00	71,34	30015014	9,1	16 $\pm 0,26$	40	12	18,3	0,23
15	5/8" x 3/8"	83,00	76,36	30015015	9,1	16 $\pm 0,26$	40	12	18,3	0,27
17	5/8" x 3/8"	93,00	86,39	30015017	9,1	16 $\pm 0,26$	40	12	18,3	0,36
13	3/4" x 7/16"	87,50	79,59	30019013	11,1	16 $\pm 0,26$	40	12	18,3	0,34
15	3/4" x 7/16"	99,80	91,63	30019015	11,1	16 $\pm 0,26$	40	12	18,3	0,47
12	1" x 17.02	109,00	98,14	30025012	16,2	20 $\pm 0,1$	47	14	17,7	0,72
13	1"1/4 x 3/4"	147,80	132,65	30031013	18,5	25 $\pm 0,1$	52	15	21,0	1,64

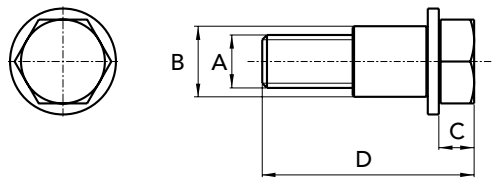

TYPE	P. NUMBER	A	B	C	D	Kg.
KIT TN 16	KTN16	M12	16	8	48	0,06
KIT TN 20	KTN20	M12	20	8	53	0,07

The securing kit Series TN, providing an easy assembly of the chain tensioner TN with our automatic tensioners Series T, AS, L.

The kit is composed by hexagonal head screw, washer and bushing.